

HOME

ADAPTATIONS FOR
SENIORS'
INDEPENDENCE

ASSESSMENT



HOME TO CANADIANS
Canada

Occupant signature required for leased property only.

Applicant, please print your name
Occupant Signature

FOR OFFICE USE ONLY
Account No.

INTRODUCTION

This assessment has been created to help in identifying the best adaptations for the difficulties encountered.

The assessment should therefore be completed by the occupant of the dwelling where modifications/adaptations will be made. Where the dwelling requiring adaptations is rented, the tenant should be asked to complete the assessment.

The assessment can also be completed by an occupational therapist, a health care worker or a social services professional in regular contact with the occupant.

HOW TO ANSWER A QUESTION

The assessment has a number of different sections. Each section deals with a different area of the home where a senior may have difficulty. A list of the sections can be found in the Table of Contents. The only sections you need to read through are the ones dealing with an area where you personally have difficulty.

Within each section, for one or more common daily activities, you are asked to indicate whether you have any difficulty. If your answer is no you need only check the **'NO'** box and go to the next question.

If your answer is yes, you should check the **'YES'** box and then read the list of adaptations which appears below. If any adaptation would help your difficulty, check the adjacent box.

Be selective in choosing the adaptations. Remember, the amount of assistance that may be available is limited to a maximum of \$3500. If you choose too many you can easily exceed the limit. Focus on the major problem areas.

There are spaces for you to fill in your own adaptation, if you have a special idea in mind. CMHC will decide if it is eligible under the program rules. Remember, portable devices are not eligible. Items must be housing related, permanently fixed or give access to facilities in the home.

Section 1	:	GETTING IN AND OUT OF THE DWELLING _____	1
Section 2	:	USING THE STAIRS _____	4
Section 3	:	GETTING AROUND HALLWAYS _____	5
Section 4	:	USING THE KITCHEN _____	7
Section 5	:	USING THE BATHROOM _____	11
Section 6	:	GETTING OUT OF THE BED / CHAIR _____	17
Section 7	:	USING CLOSETS AND STORAGE AREAS _____	18
Section 8	:	DOING LAUNDRY _____	19
Section 9	:	USING THE TELEPHONE / ANSWERING THE DOOR _____	20
Section 10	:	CONTROLLING LIGHT AND VENTILATION _____	23

HOME ADAPTATIONS FOR SENIORS' INDEPENDENCE

SECTION I

GETTING IN AND OUT OF THE DWELLING

I.1 Do you have any difficulty walking from the garage, the backyard or the street to your door?

No

Yes



Check the work items below which would help you

01101

Widen walkway

01102

Add steps to remove steep slope

01103

Add a ramp to existing steps

01104

Install/repair handrails along walkway/slope / step

01105

Provide non-slip finish on walking surfaces

0119X

Other (describe)

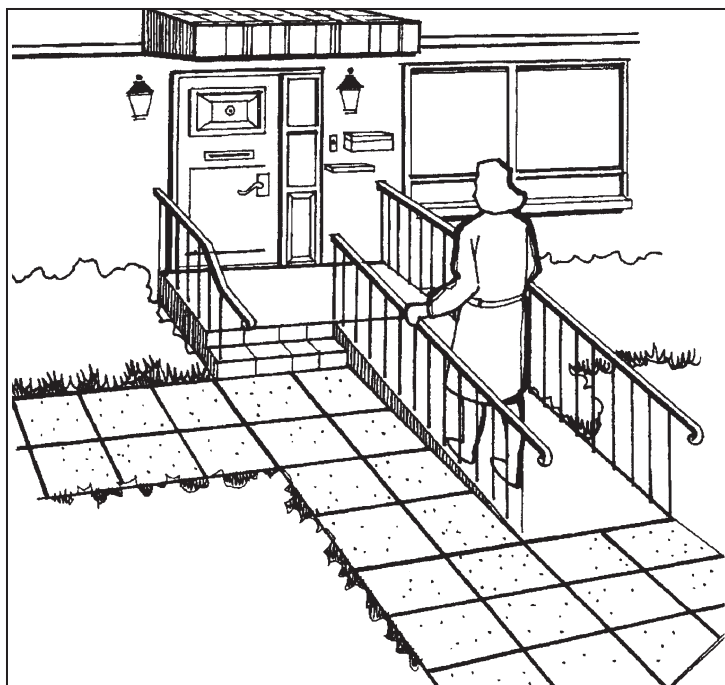

A ramp next to existing steps gives the option to a person with a walker or a wheelchair. Handrails along the entranceway guide and support persons with poor vision or balance.

Go to next question

I.2 Do you have any difficulty with lighting along the walkway leading to your home?

No

Yes 

Check the work items below which would help you

01201 **Install light fixtures or flood-lights along entrance walkway steps/stairs**

01202 **Install light switches or sensors to control outside lights**

0129X **Other (describe)**

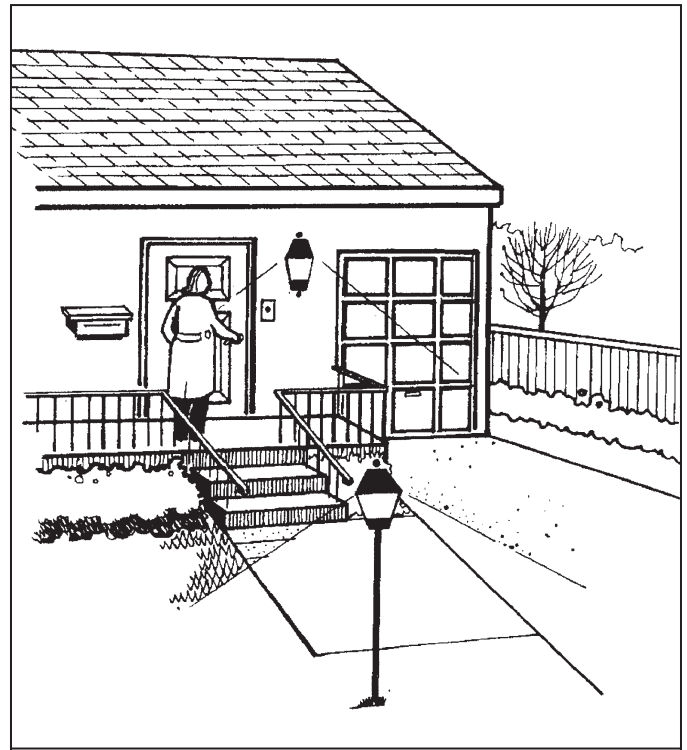

Well lighted walkway and steps, colour contrasts, help people with poor vision to detect obstacles.

Go to next question

1.3 Do you have any difficulty with outside doors?

No

Yes 

Check the work items below which would help you

- 01301 **Remove screen door**
- 01302 **Reduce height of door threshold and adjust or replace door accordingly**
- 01303 **Add a grab bar or handle near step or threshold**
- 01304 **Install a delayed action door closer**
- 01305 **Replace locks to improve function or increase security**
- 01306 **Install lever type door handles**
- 01307 **Install a small shelf inside and outside front door at elbow height to hold parcels while opening door**
- 01308 **Use color contrast on door, door frame, handle, or doorbell**
- 0139X **Other (describe)**

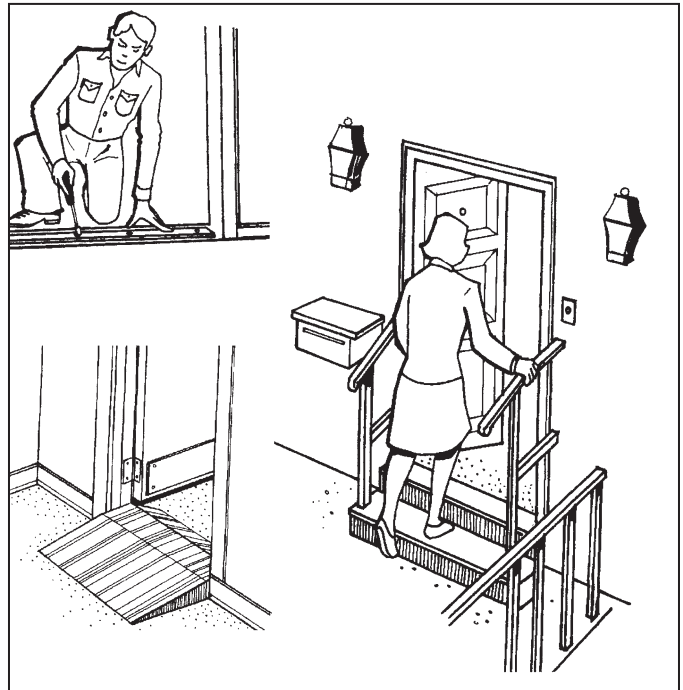

A flat threshold with a soft vinyl strip in the centre, a small ramp or an extra step with a grab bar or handrails are possible solutions for dealing with high door thresholds.

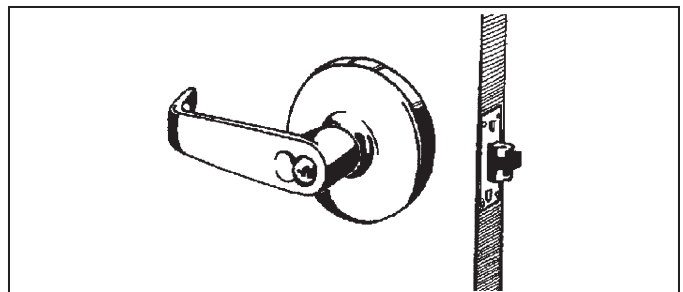

A lever handle makes grasping and pulling easier for people with poor grip. A single-action, dead-bolt lock is secure and only requires the use of one hand.

Go to next question

2.1 Do you have any difficulty using the stairs inside your home?

 NoYes 

Check the work items below which would help you

- 02101 Increase lighting in stairs
- 02102 Install light switches at top and bottom of stairs
- 02103 Install / repair handrails
- 02104 Extend handrails beyond the top and bottom of steps
- 02105 Repair or replace stair covering with a non-slip surface
- 02106 Install colour contrasts or change in texture at top and bottom of stairs and on the edge of each step
- 02107 Relocate bedroom to main floor level
- 02108 Relocate laundry room to the main floor level
- 02109 Relocate or add a toilet on main floor or bedroom level
- 0219X Other (describe)



Well lighted staircase with solid handrails extending beyond the top and bottom of stairs, strong colour contrast or changes in texture at the top or bottom make it safer and easier for people with poor balance or people with poor vision.

Go to next
question

3.1 Do you have any difficulty moving from one room to another?

No

Yes



Check the work items below which would help you

03101

Reduce height of, or eliminate door threshold at room entrances

03102

Use color contrast or changes in floor texture wherever there is a change of level

03103

Install "swing clear hinge" on doors to widen doorways

03104

Install handrails or grab bars where changes in floor level are present

03105

Install handrails along walls

0319X

Other (describe)

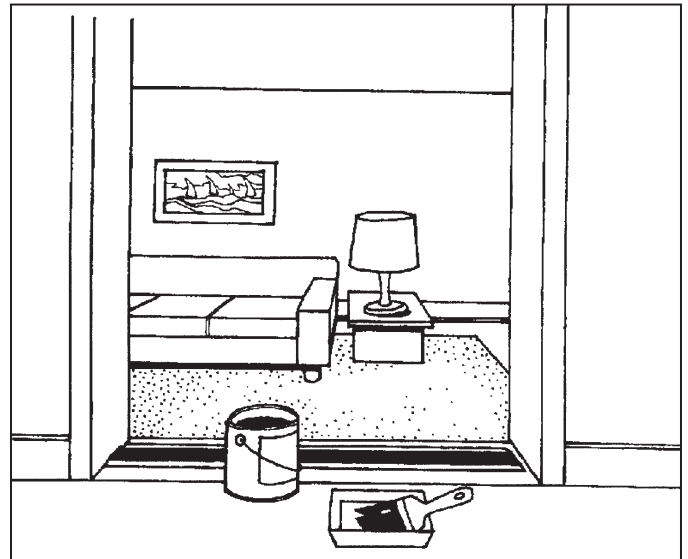

Strong colour contrast strip on edge of step or threshold or changes in floor texture between rooms, will help people with poor vision detect possible obstacles.

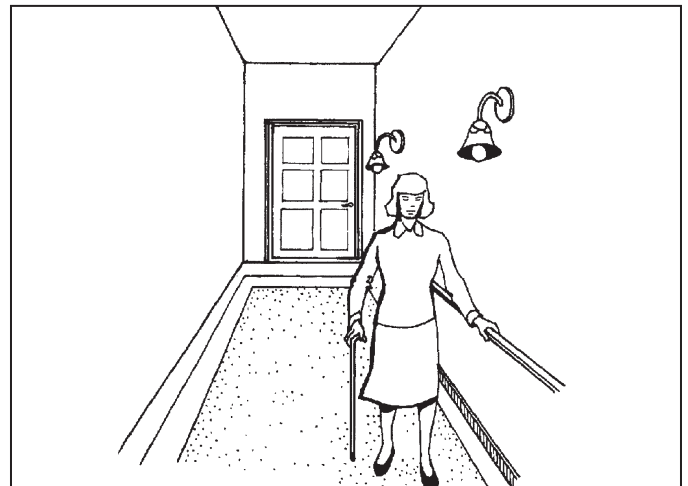

Handrails along corridors help people with poor balance.

Go to next question

3.2 Do you have any difficulty with doors?

No

Yes



Check the work items below which would help you

03201

Repair door frame or door hinges

03202

Reverse direction of door swing

03203

Replace door knobs with lever type door handles

03204

Install sliding, bi-folding or accordion door in closets, pantry

03205

Install 'D' type handles or loop handles on bi-folding, sliding or accordion doors

0329X

Other (describe)

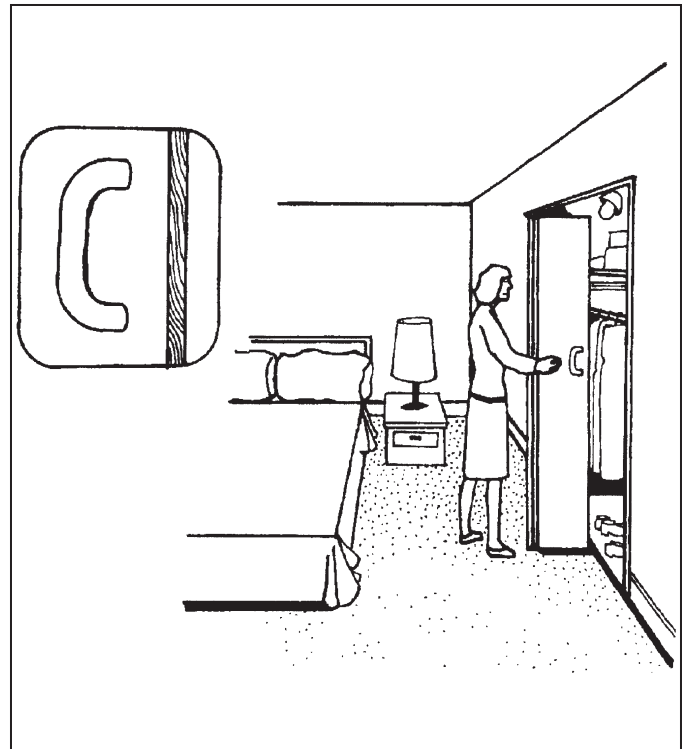

A large hand in a "D" shape is easy to pull for people with decreased movement and strength in their hands.

Go to next question

4.1 Do you have any difficulty working at the sink or using the faucets?

No

Yes 

Check the work items below which would help you

04101

Adjust sink to a convenient height

04102

Open the space under sink for working in a seated position (insulate plumbing)

04103

Install lever type faucets or faucet with single lever to control water flow and temperature

04104

Relocate/install faucets for easier access

0419X

Other (describe)

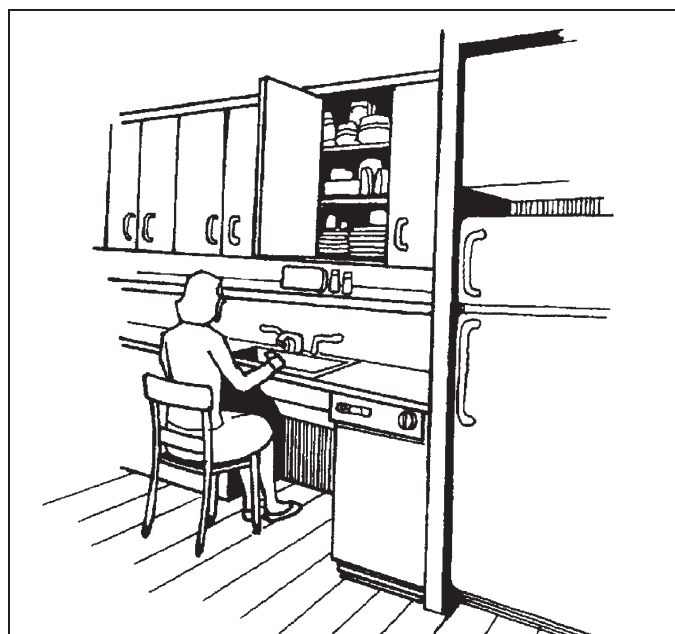

If you usually stand while using the sink, the sink should be at a height requiring minimal bending. If you wish to sit while using the sink, there should be space under the sink for knees and the sink should be at a height requiring minimal stretching.

Go to next
question

4.2 Do you have any difficulty working at the counter?

No

Yes 

Check the work items below which would help you

04201

Adjust counter height to your level

04202

Install additional counter/storage space

04203

Install pull-out shelves under counter for working in a seated position

04204

Remove a cupboard to create space under counter for working in a seated position

0429X

Other (describe)

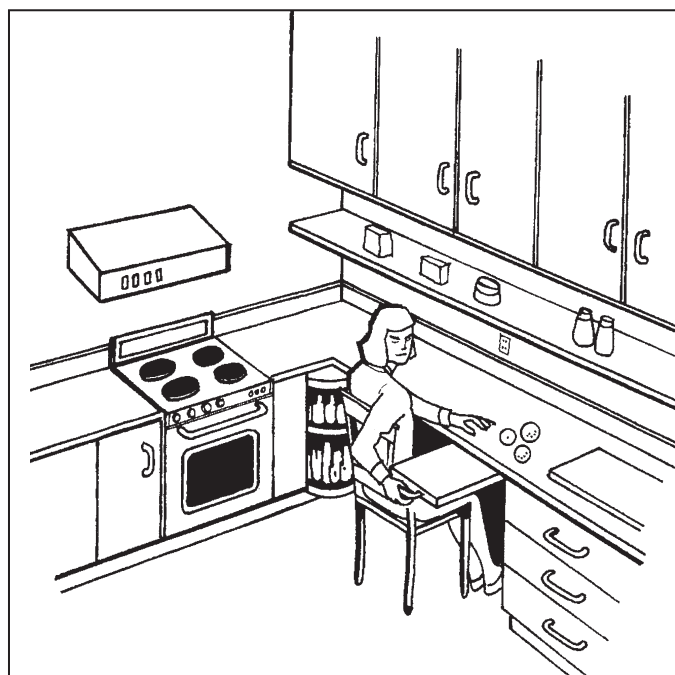

Pull-out shelves are ideal to allow food preparation in a seated position. "U" or "L" shaped counters, cut down the amount of necessary walking.

Go to next question

4.3 Do you have any difficulty reaching or using cupboards or storage space?

 No

 Yes

Check the work items below which would help you

- 04301 Lower existing cupboards
- 04302 Lower shelves in cupboards
- 04303 Add cupboards or shelves at a convenient height
- 04304 Add a vertical cupboard or pantry
- 04305 Add pull-out storage units under counter
- 04306 Install "D" type handles on cupboards or drawers
- 0439X Other (describe)

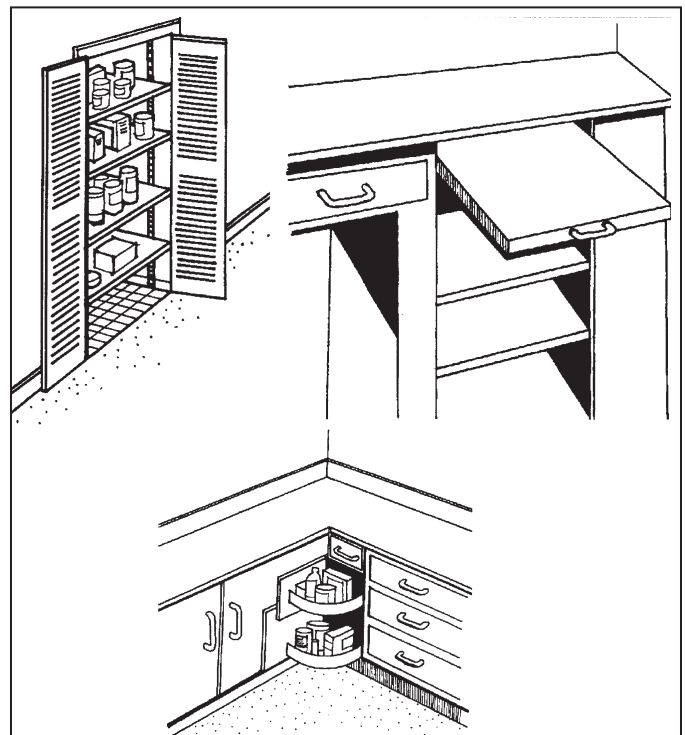

Pivoting shelves in corners, pull-out storage units and large vertical cabinets make storage more accessible.

Go to next question

4.4 Do you have any difficulty using appliances?

No

Yes



Check the work item below which would help you

04401

Install shelves or counter top to accommodate small appliances

04402

Provide electrical outlets to use small appliances in a more convenient location

04403

Provide heat-proof, pull-out shelf beside oven

04404

Install a heat-proof insert on counter

04405

Install smoke/heat detectors outside kitchen

04406

Install a fire extinguisher near kitchen exit

0449X

Other (describe)

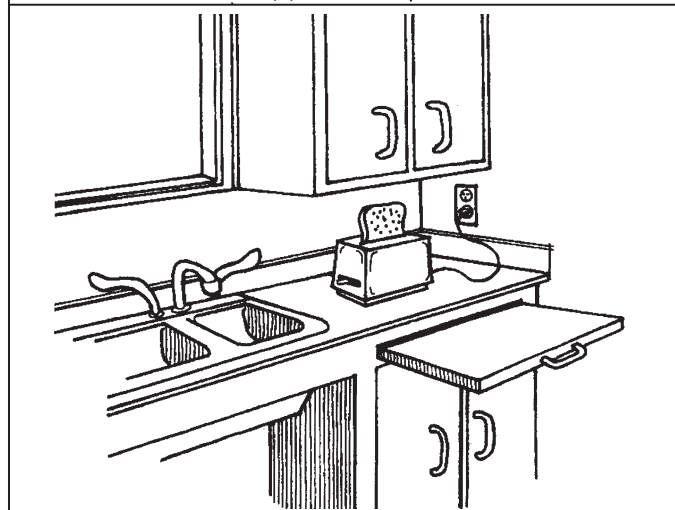
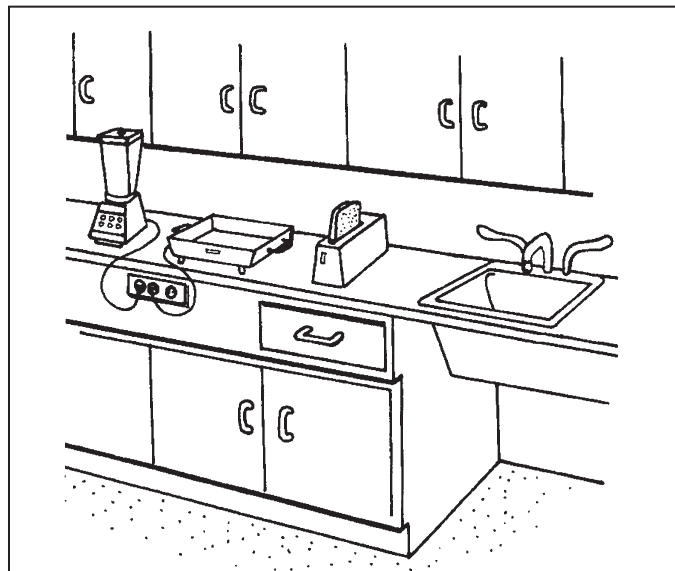

Installing electrical outlets at convenient locations reduces the need to carry small kitchen appliances back and forth.

Go to next question

5.1 Do you have any difficulty using the wash basin or the faucets?

No

Yes



Check the work items below which would help you

05101

Adjust wash basin to a convenient height

05102

Create space for knees under basin for washing in a seated position (insulate plumbing)

05103

Strengthen basin with legs or solid cabinet

05104

Install faucet with single lever to control water flow and temperature

05105

Relocate faucet to front or side for easier access

0519X

Other (describe)

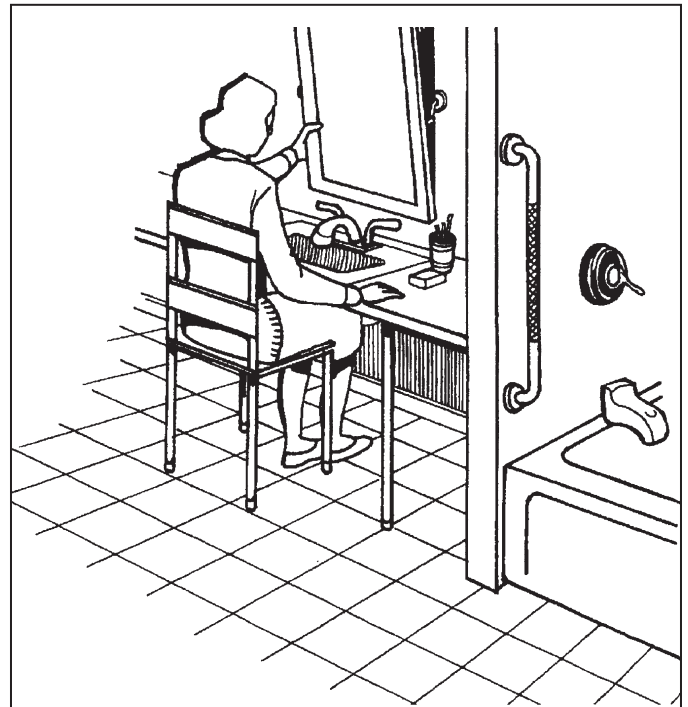

If you tend to lean, pull or push against basin, it may need to be strengthened. A cabinet can be designed to allow working in a seated position.

Go to next question

5.2 Do you have any difficulty using/storing personal care items near wash basin?

No

Yes



Check the work items below which would help you

05201

Install additional counter space around basin

05202

Install shelves beside basin for storage

05203

Install a grab bar within easy reach

05204

Install/adjust a mirror at a convenient height, tilted if necessary

05205

Install additional light fixtures near mirror or medicine cabinet

0529X

Other (describe)

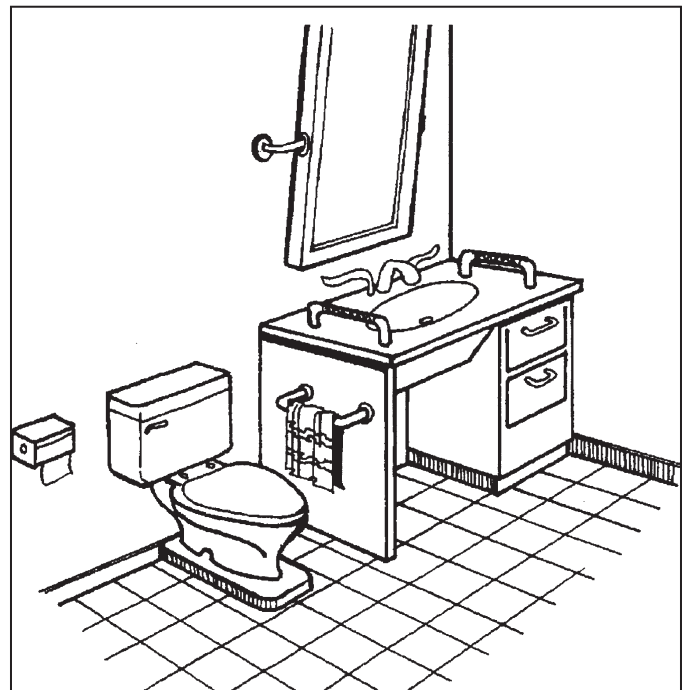

The mirror should be tilted or adjusted to a convenient height (when sitting, standing or both according to preference) for grooming or washing.

Go to next question

5.3 Do you have any difficulty stepping into/out of the bathtub?

No

Yes 

Check the work items below which would help you

- 05301 **Install a vertical and a horizontal or angled grab bar by tub**
- 05302 **Install non-slip flooring throughout the bathroom**
- 05303 **Install non-slip surface bathtub**
- 05304 **Install a commercial or custom made transfer bench to enter tub in a seated position**
- 05305 **Replace bathtub with a shower stall if difficulty is severe**
- 05306 **Install a separate shower stall if difficulty is severe**
- 0539X **Other (describe)**

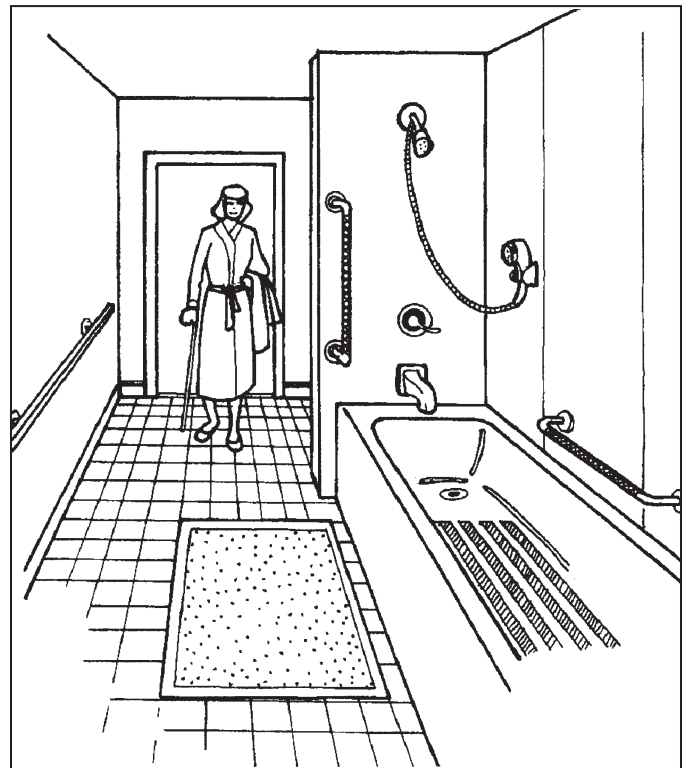

A vertical grab bar at tub entrance gives a first support while the horizontal grab bar along wall will help you complete the entrance and lower yourself onto shower seat or to bottom of tub.

Go to next question

5.4 Do you have any difficulty using tub faucets, shower controls or drain plug?

No

Yes



Check the work items below which would help you

05401

Install lever type faucets or faucet with single action to control flow

05402

Adjust the hot water heater or install a device that will prevent too hot a water temperature

05403

Install a plug mechanism, operated from a convenient height

0549X

Other (describe)



A single mixing control with a lever handle, for shower and bath, is easier for people who have difficulty grasping things.

Go to next question

5.5 Do you have any difficulty taking a bath or a shower?

 No

 Yes 

Check the work items below which would help you

- 05501 **Install hand-held shower on adjustable rod or high-low mounting brackets**
- 05502 **Install a flip-up seat in tub or shower**
- 05503 **Install shelves within reach, for personal care items**
- 05504 **Install a grab bar within reach**
- 05505 **Install a waterproof light fixture over tub or in shower stall**
- 0559X **Other (describe)**

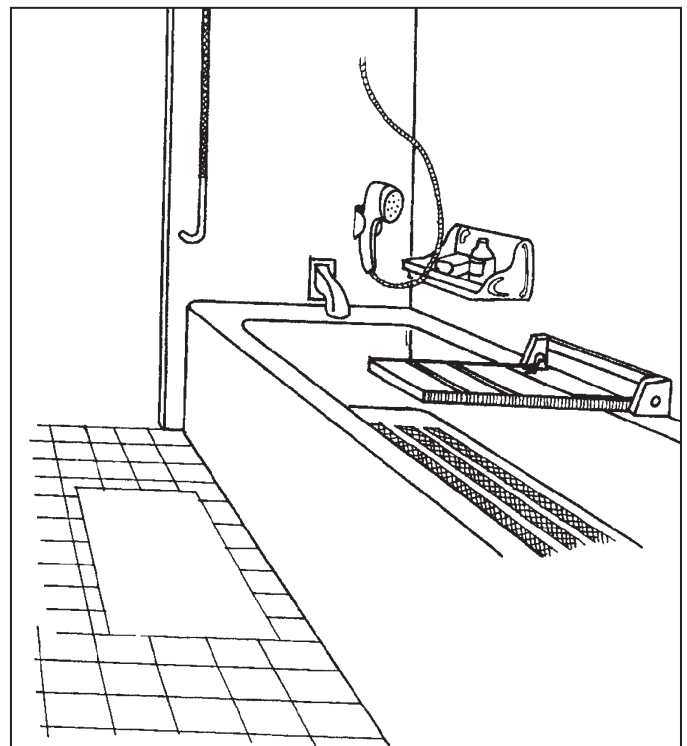

When using a shower seat, a hand held shower, mounted on a vertical rod or on a low bracket makes washing and rinsing easier.

Go to next question

5.6 Do you have any difficulty using the toilet?

No

Yes



Check the work items below which would help you

05601

Adjust toilet to a convenient height (raise the toilet, or replace it with a higher model)

05602

Install grab bars

05603

Adapt or relocate flush mechanism

05604

Adapt or relocate toilet paper dispenser

0569X

Other (describe)

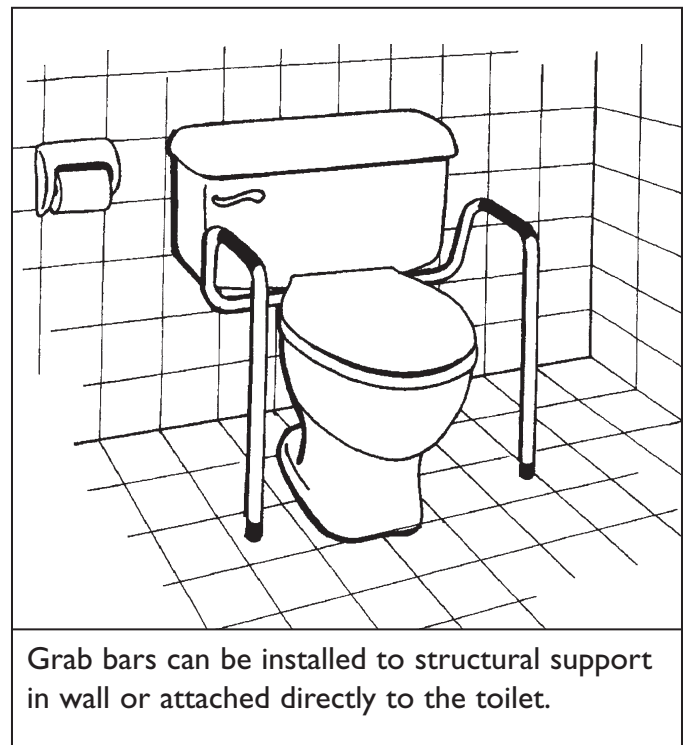

Go to next question

6.1 Do you have any difficulty getting in and out of bed, chair or sofa?

No

Yes 

Check the work items below which would help you

06101

Install grab bars or vertical pole in convenient locations

06102

Install a trapeze over bed

0619X

Other (describe)

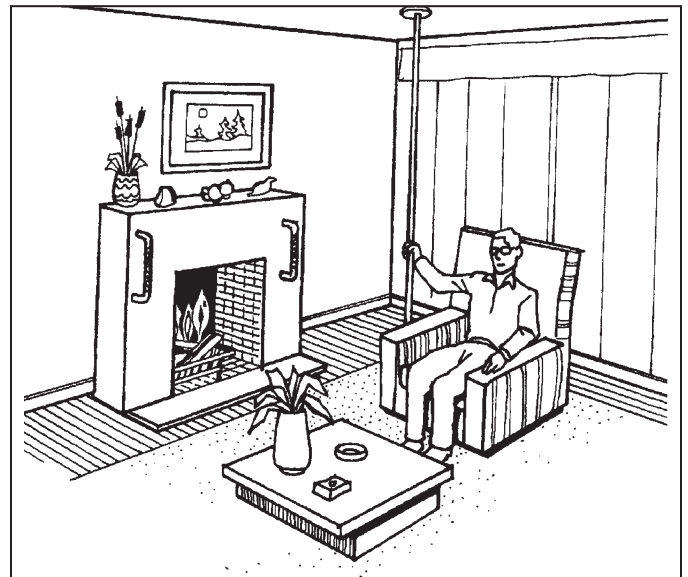
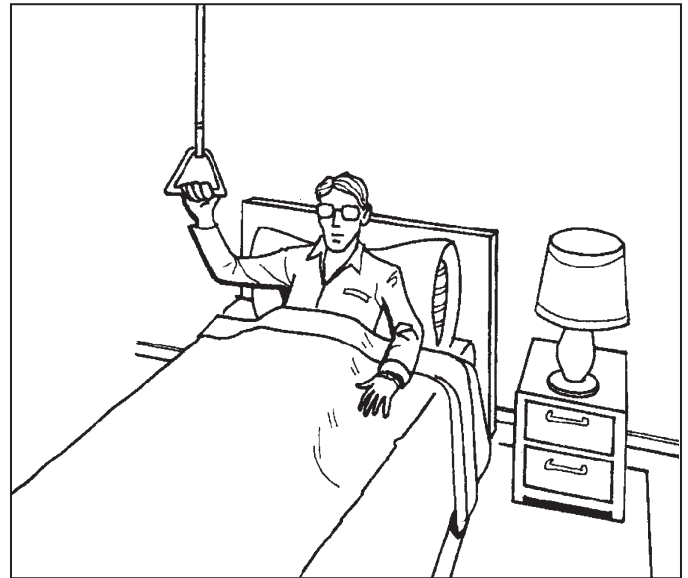

Go to next
question

7.1 Do you have any difficulty reaching clothes, coats, shoes or other items in closet?

No

Yes 

Check the work items below which would help you

07101

Install bi-folding or accordion doors

07102

Install a light in closets

07103

Add or lower rods

07104

Add or lower shelves

07105

Add off-floor shelves in closets or at front entrance for shoes, boots

07106

Install hooks, shelves or drawers in closets

07107

Build an easy-to-access storage closet for household appliances such as vacuum cleaner, ironing board

0719X

Other (describe)

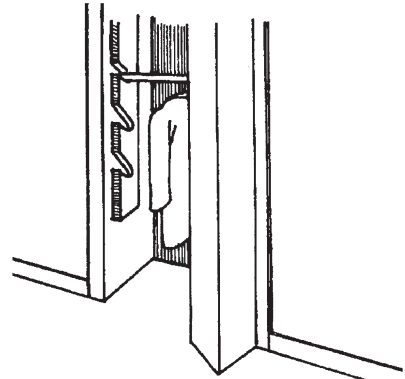
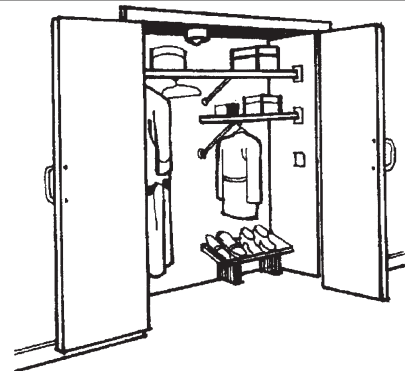

Reachable shelves in bedroom or entrance closet, and a well designed utility closet for vacuum cleaner, iron or ironing board help people who cannot reach very high or who have difficulty bending.

Go to next
question

8.1 Do you have any difficulty doing the laundry?

No

Yes 

Check the work items below which would help you

08101

Relocate appliances to a more convenient place

08102

Provide shelves or storage near appliances for keeping washing supplies at a more convenient place

08103

Build a counter or large shelves near appliances for sorting out or folding clothes

08104

Install electrical outlets and outside connections for a dryer

08105

Install or adjust clothesline to a convenient height

08106

Install a rod for hanging clothes

0819X

Other (describe)

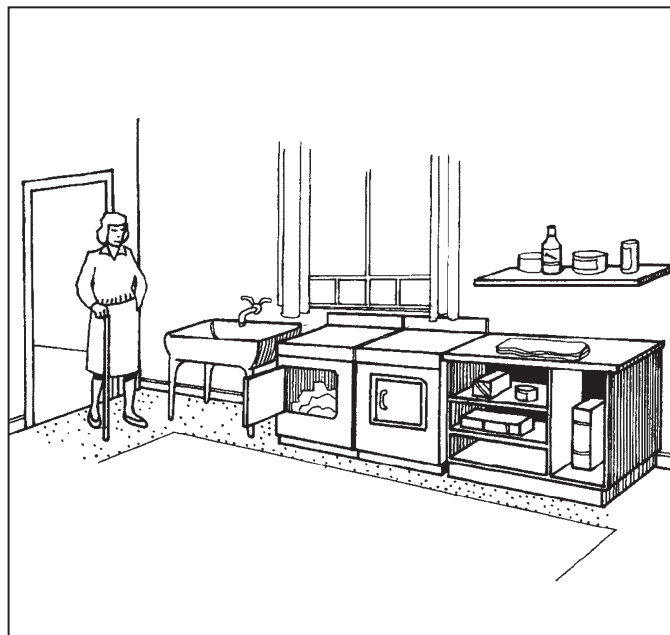

A countertop near the washer and dryer cuts down the number of times you have to move your laundry.

Go to next
question

9.1 Do you have any difficulty getting to the telephone on time?

No

Yes



Check the work items below which would help you

09101

Install phone jacks in convenient locations and at convenient height (near bed, sofa)

0919X

Other (describe)

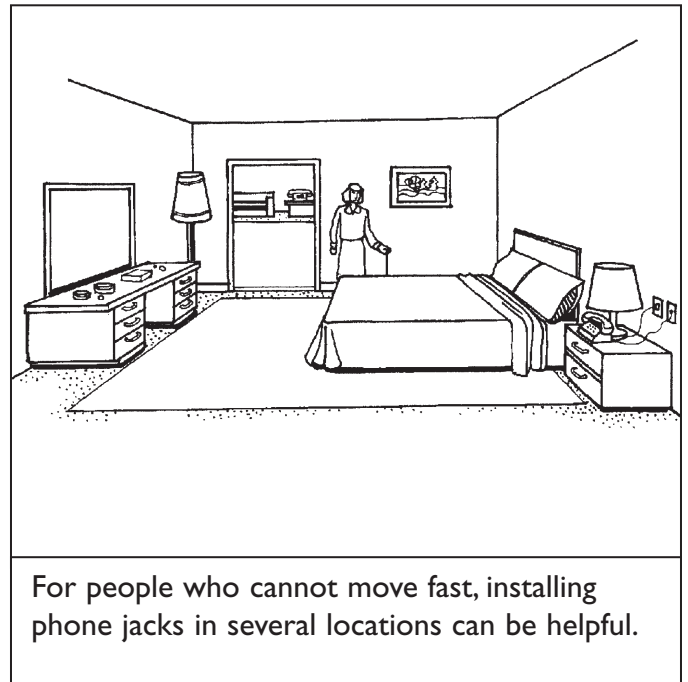

Go to next question

9.2 Do you have any difficulty identifying visitors and/or hearing doorbell?

No

Yes



Check the work items below which would help you

09201

Install a peephole or view panel at a convenient height

09202

Install an easy-to-use intercom at a convenient height

09203

Install a flashing light or other sensory cue to doorbell

0929X

Other (describe)

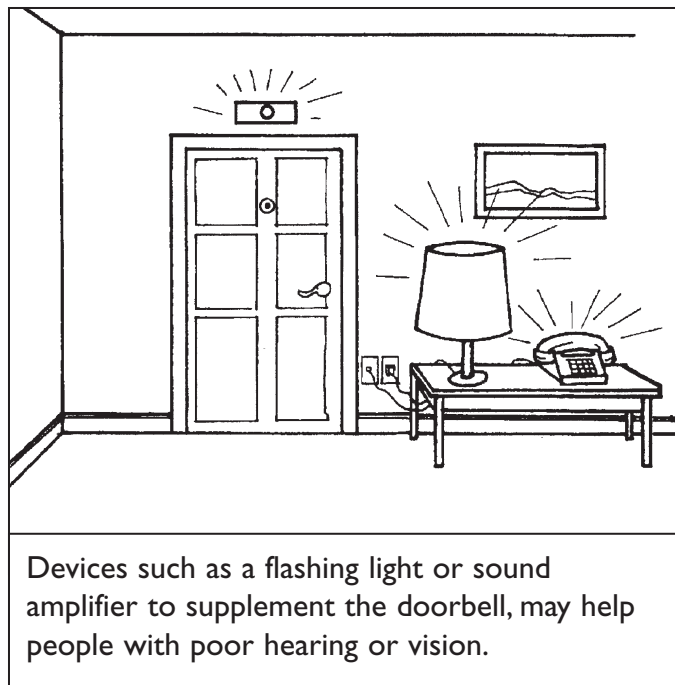

Go to next question

9.3 Do you have any difficulty reaching and emptying the mailbox?

No

Yes



Check the work items below which would help you

09301

Install the mailbox at a convenient height

09302

Install a mail slot with a box or bag on the inside to collect the mail

09303

Install a shelf near mailbox to hold parcels

0939X

Other (describe)

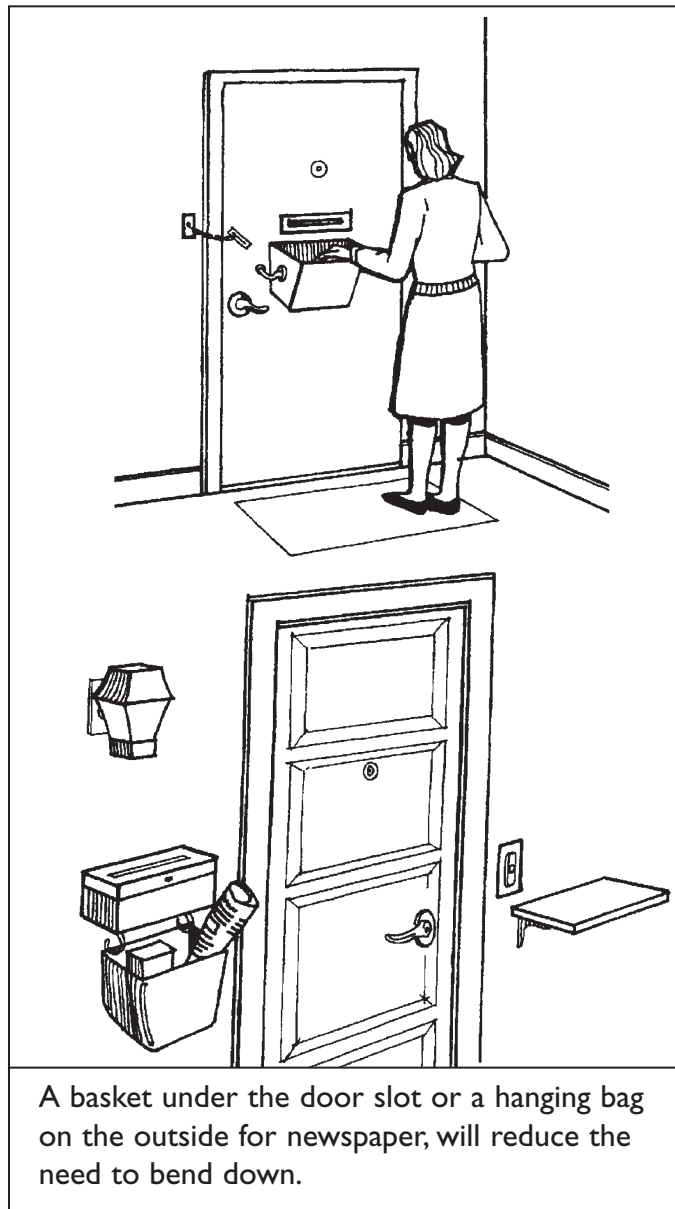

Go to next question

10.1 Do you have any difficulty with lighting in areas of the home not mentioned previously?

No

Yes



Check the work items below which would help you

10101

Install light fixtures or electric outlets for lamps where needed, e.g. in hallways, in working areas, in pantry, near reading or activity area (sofa, bed)

10102

Install light switches at convenient locations e.g. room entrances, near bed, sofa, at both ends of corridors, top and bottom of staircase

1019X

Other (describe)

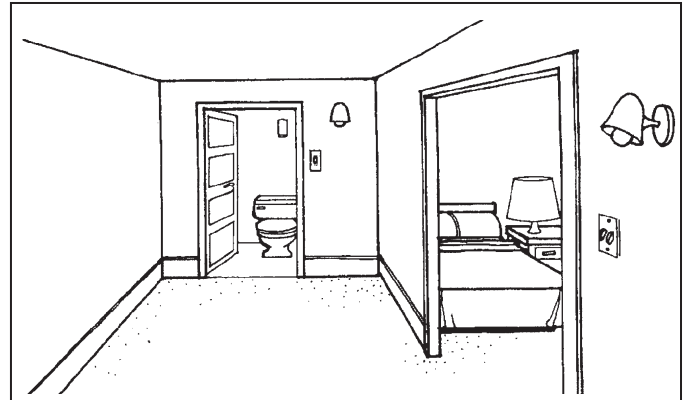

Light switches at doorways and two-way switches will minimize the need to walk across a dark hallway and move into a dark room e.g. bathroom.

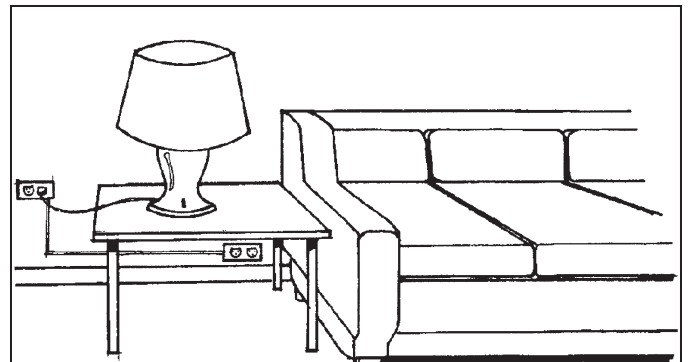

Additional electrical outlets at a height not requiring much bending will not require extension cords to tables lamps. They can also help use small appliances (vacuum cleaner, iron, sewing machine, etc.)

Go to next question

10.2 Do you have any difficulty with windows?

No

Yes 

Check the work items below which would help you

- 10201 **Install easy-to-grasp window handles**
- 10202 **Install secure and easy-to-operate lock**
- 10203 **Repair window so that it opens and closes easily**
- 10204 **Install unbreakable windows or security bars at windows vulnerable to forced entry**
- 1029X **Other (describe)**

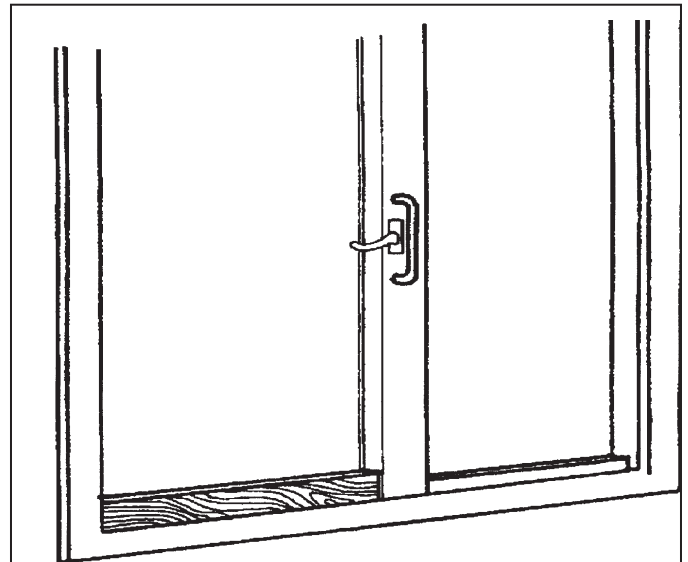

Large "D" type handles on window and extension arm on window lock are easier to grip for people with decreased strength and movement in the hand.

Canada Mortgage and Housing Corporation (CMHC) offers a wide range of housing-related information. For details, contact your local CMHC office.

CMHC subscribes to the sustainable development theme of the federal government. Quantities of our publications are limited to market demand; updates are produced only when required; and recycled or environmentally friendly stock and environmentally safe inks are used wherever possible.

**Cette publication est aussi disponible en français sous le titre :
Logements adaptés : Aînés autonomes Évaluation - 60584**

